

No	MATERIALS LIST:
1.	CABLE:USB AOC (4 Fiber + 4 Copper) OD:4.5mm PVC JACKET COLOR:BLUE
2.	CABLE:UL20276 (32AWG*1PR+D+AM)x2C+32AWG*1PR+24AWG*1C+AM+B OD:4.2mm PVC JACKET COLOR:BLUE
3.	CABLE:28AWGx2C OD:3.0mm PVC JACKET COLOR:BLUE
4.	CONNECTOR:USB 3.0 A/M, 9P, BLUE INSULATOR SOLDER TYPE, NICKEL PLATED SHELL
5.	CONNECTOR:USB 3.0 B/M, 9P, BLACK INSULATOR SOLDER TYPE, NICKEL PLATED SHELL
6.	DC JACK
7.	ABS ASSEMBLY HOUSING, BLUE COLOR
8.	PVC MOLDED HOUSING, BLUE COLOR

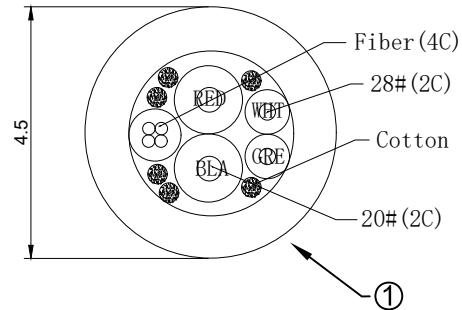

Jargy part no.	Client part no.	Approved	SCALE	UNIT
CBL-U3AOC02N-xm				mm
Drawing Name		Drawn	Date	REV.
USB 3.0 A to B Device Cable M/M				1.0

**Mobile Computing** **JARGY**

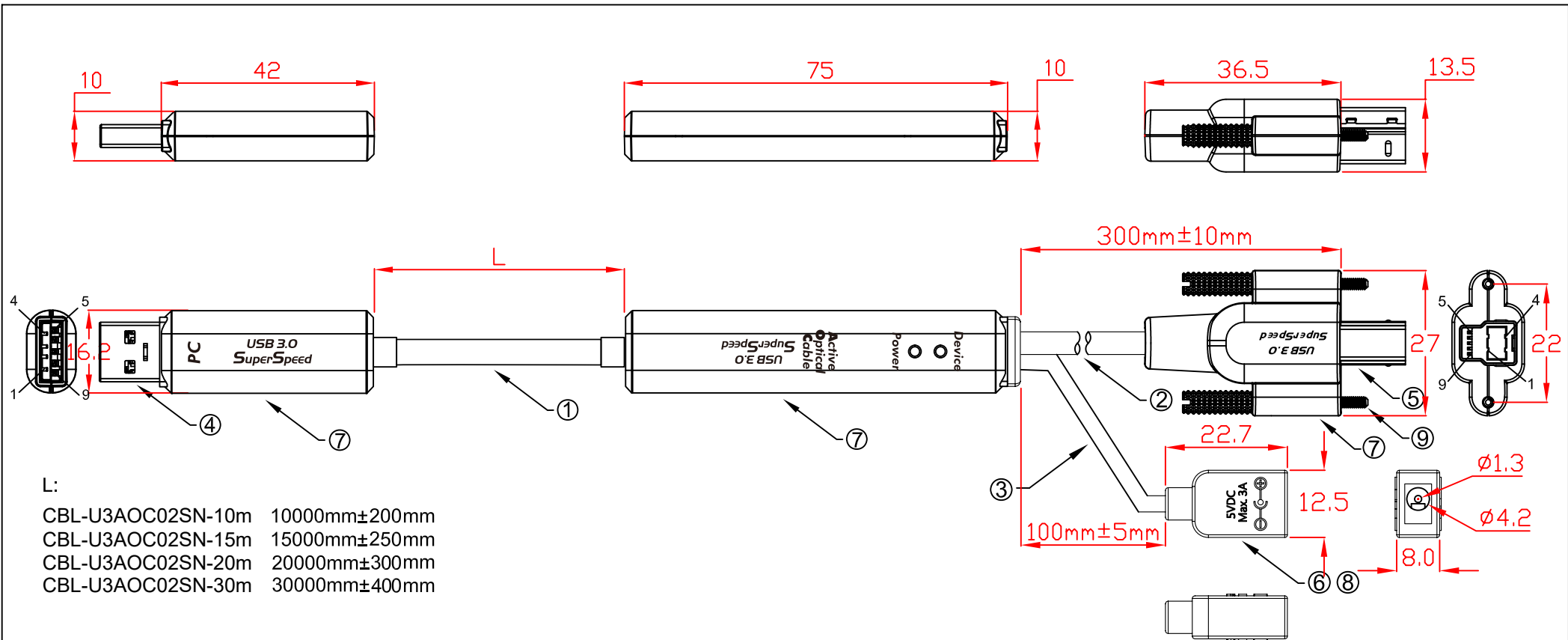

- L:
- CBL-U3AOC02SN-10m 10000mm±200mm
  - CBL-U3AOC02SN-15m 15000mm±250mm
  - CBL-U3AOC02SN-20m 20000mm±300mm
  - CBL-U3AOC02SN-30m 30000mm±400mm

No	MATERIALS LIST:
1.	CABLE:USB AOC (4 Fiber + 4 Copper) OD:4.5mm PVC JACKET COLOR:BLUE
2.	CABLE:UL20276 (32AWG*1PR+D+AM)x2C+32AWG*1PR+24AWG*1C+AM+B OD:4.2mm PVC JACKET COLOR:BLUE
3.	CABLE:28AWGx2C OD:3.0mm PVC JACKET COLOR:BLUE
4.	CONNECTOR:USB 3.0 A/M, 9P, BLUE INSULATOR SOLDER TYPE, NICKEL PLATED SHELL
5.	CONNECTOR:USB 3.0 B/M, 9P, BLACK INSULATOR SOLDER TYPE, NICKEL PLATED SHELL
6.	DC JACK
7.	ABS ASSEMBLY HOUSING, BLUE COLOR
8.	PVC MOLDED HOUSING, BLUE COLOR

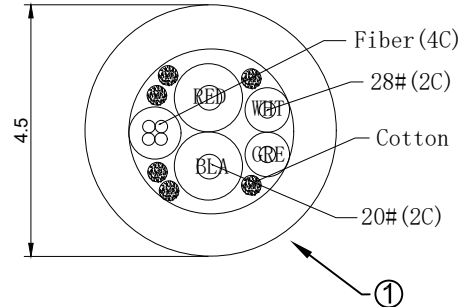

Jargy part no.	Client part no.	Approved	SCALE	UNIT
CBL-U3AOC02SN-xm				mm
Drawing Name		Drawn	Date	REV.
USB 3.0 A to B Device Cable M/M				1.0

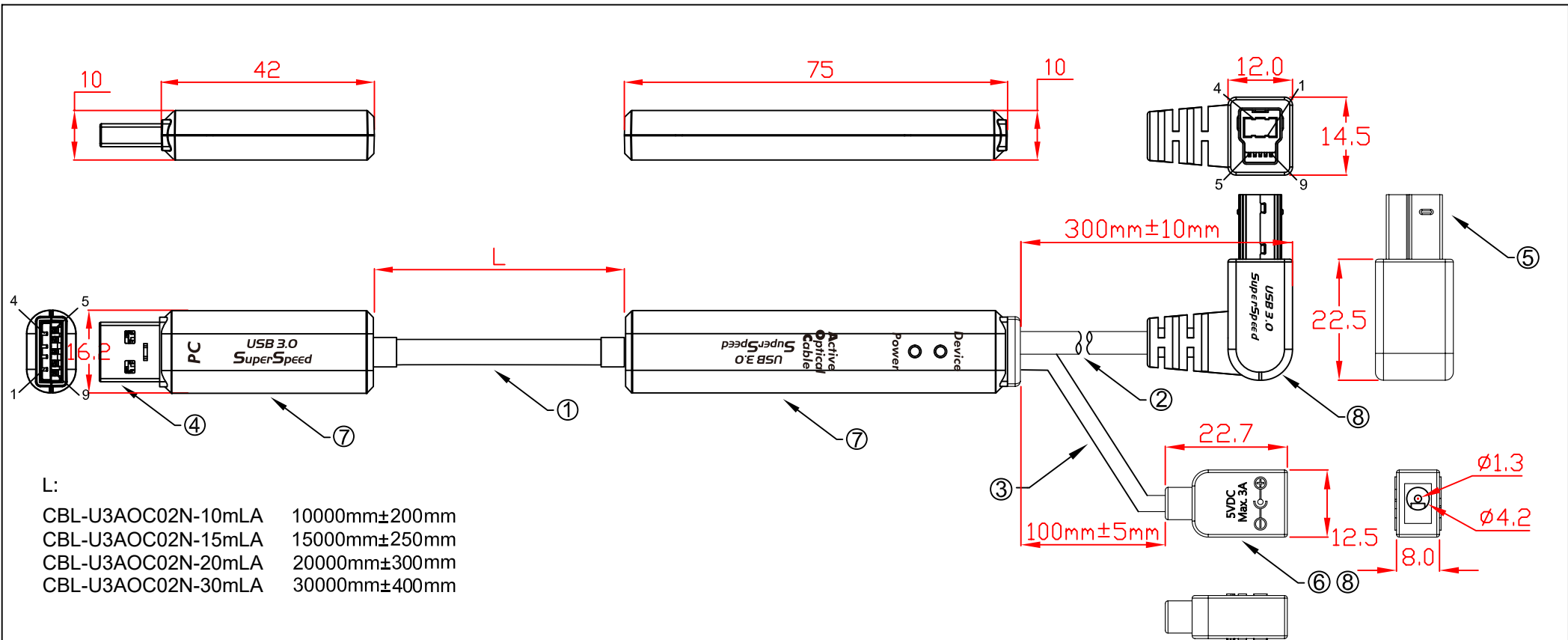

L:

CBL-U3AOC02N-10mLA	10000mm±200mm
CBL-U3AOC02N-15mLA	15000mm±250mm
CBL-U3AOC02N-20mLA	20000mm±300mm
CBL-U3AOC02N-30mLA	30000mm±400mm

No	MATERIALS LIST:
1.	CABLE:USB AOC (4 Fiber + 4 Copper) OD:4.5mm PVC JACKET COLOR:BLUE
2.	CABLE:UL20276 (32AWG*1PR+D+AM)x2C+32AWG*1PR+24AWG*1C+AM+B OD:4.2mm PVC JACKET COLOR:BLUE
3.	CABLE:28AWGx2C OD:3.0mm PVC JACKET COLOR:BLUE
4.	CONNECTOR:USB 3.0 A/M, 9P, BLUE INSULATOR SOLDER TYPE, NICKEL PLATED SHELL
5.	CONNECTOR:USB 3.0 B/M, 9P, BLACK INSULATOR SOLDER TYPE, NICKEL PLATED SHELL
6.	DC JACK
7.	ABS ASSEMBLY HOUSING, BLUE COLOR
8.	PVC MOLDED HOUSING, BLUE COLOR

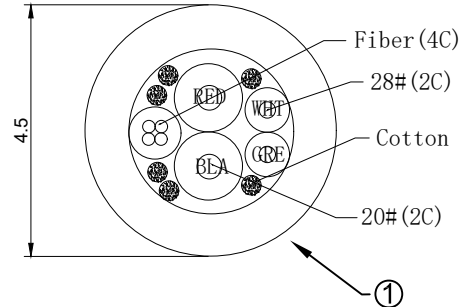

Jargy part no.	Client part no.	Approved	SCALE	UNIT
CBL-U3AOC02N-xmLA				mm
Drawing Name		Drawn	Date	REV.
USB 3.0 A to B Device Cable M/M				1.0

**Mobile Computing** **JARGY**

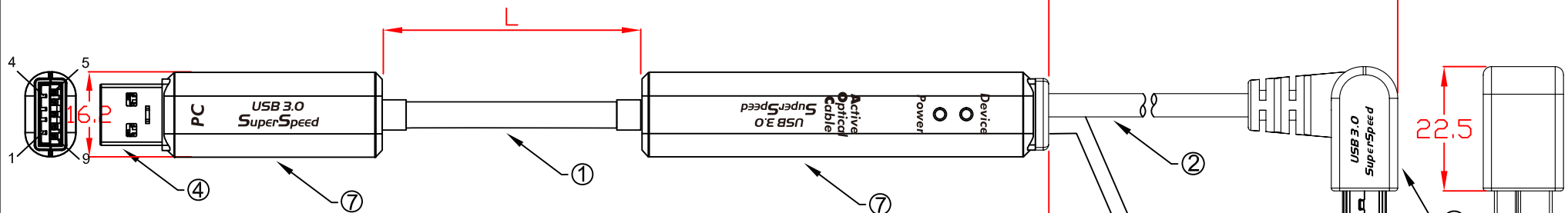
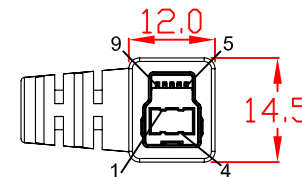
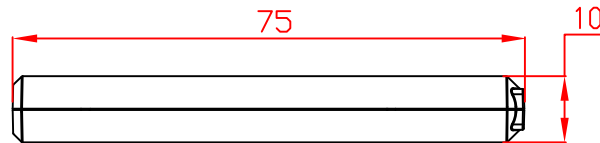
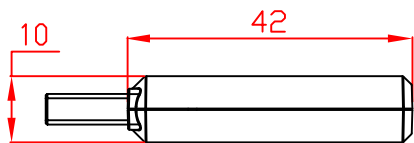

- L:
- CBL-U3AOC02N-10mRA 10000mm±200mm
  - CBL-U3AOC02N-15mRA 15000mm±250mm
  - CBL-U3AOC02N-20mRA 20000mm±300mm
  - CBL-U3AOC02N-30mRA 30000mm±400mm

No	MATERIALS LIST:
1.	CABLE:USB AOC (4 Fiber + 4 Copper) OD:4.5mm PVC JACKET COLOR:BLUE
2.	CABLE:UL20276 (32AWG*1PR+D+AM)x2C+32AWG*1PR+24AWG*1C+AM+B OD:4.2mm PVC JACKET COLOR:BLUE
3.	CABLE:28AWGx2C OD:3.0mm PVC JACKET COLOR:BLUE
4.	CONNECTOR:USB 3.0 A/M, 9P, BLUE INSULATOR SOLDER TYPE, NICKEL PLATED SHELL
5.	CONNECTOR:USB 3.0 B/M, 9P, BLACK INSULATOR SOLDER TYPE, NICKEL PLATED SHELL
6.	DC JACK
7.	ABS ASSEMBLY HOUSING, BLUE COLOR
8.	PVC MOLDED HOUSING, BLUE COLOR

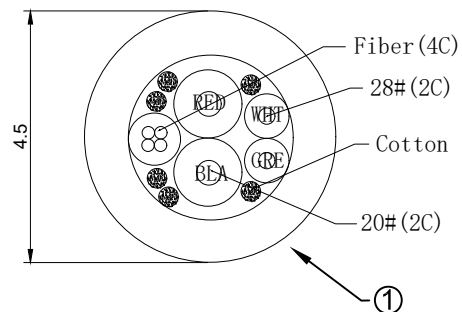

Jargy part no.	Client part no.	Approved	SCALE	UNIT
CBL-U3AOC02N-xmRA				mm
Drawing Name		Drawn	Date	REV.
USB 3.0 A to B Device Cable M/M				1.0

**Mobile Computing** **JARGY**

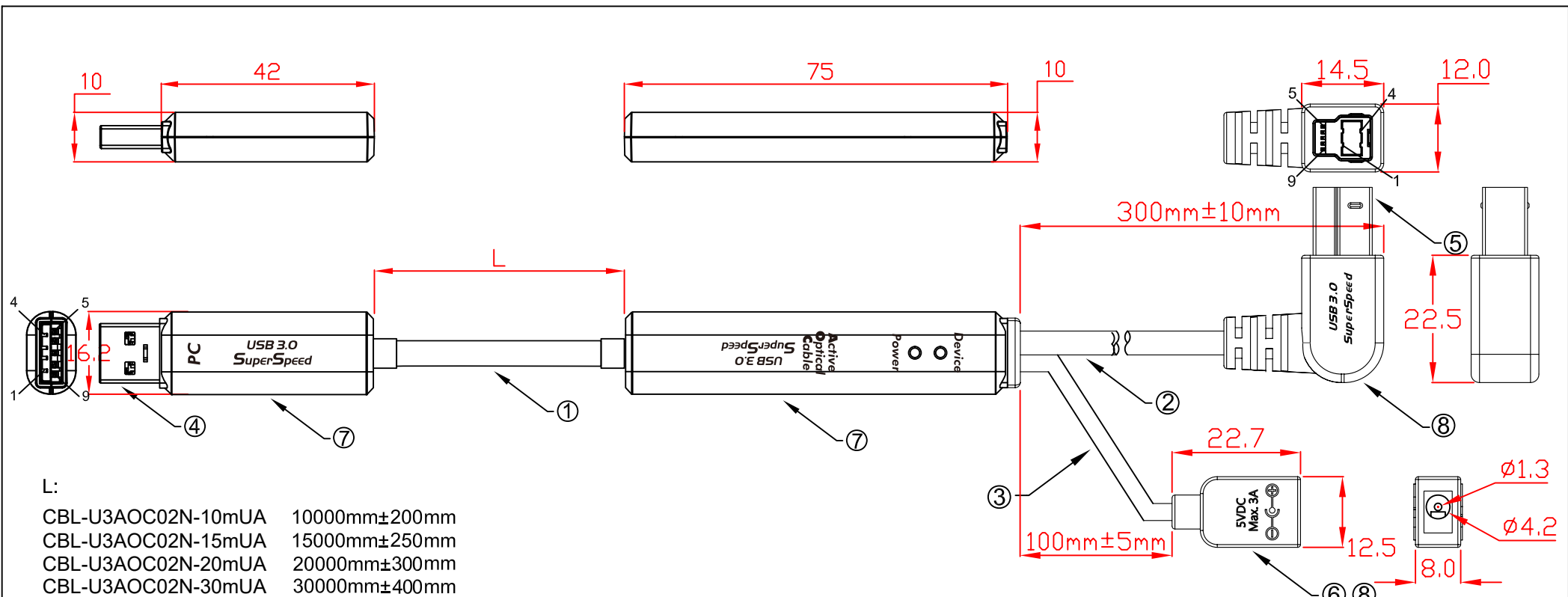

No	MATERIALS LIST:
1.	CABLE: USB AOC (4 Fiber + 4 Copper) OD:4.5mm PVC JACKET COLOR:BLUE
2.	CABLE:UL20276 (32AWG*1PR+D+AM)x2C+32AWG*1PR+24AWG*1C+AM+B OD:4.2mm PVC JACKET COLOR:BLUE
3.	CABLE:28AWGx2C OD:3.0mm PVC JACKET COLOR:BLUE
4.	CONNECTOR:USB 3.0 A/M, 9P, BLUE INSULATOR SOLDER TYPE, NICKEL PLATED SHELL
5.	CONNECTOR:USB 3.0 B/M, 9P, BLACK INSULATOR SOLDER TYPE, NICKEL PLATED SHELL
6.	DC JACK
7.	ABS ASSEMBLY HOUSING, BLUE COLOR
8.	PVC MOLDED HOUSING, BLUE COLOR

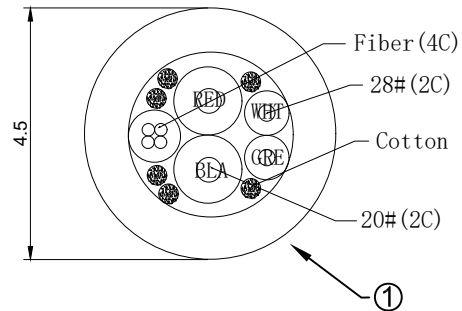

Jargy part no.	Client part no.	Approved	SCALE	UNIT
CBL-U3AOC02N-xmUA				mm
Drawing Name		Drawn	Date	REV.
USB 3.0 A to B Device Cable M/M				1.0

**Mobile Computing** **JARGY**

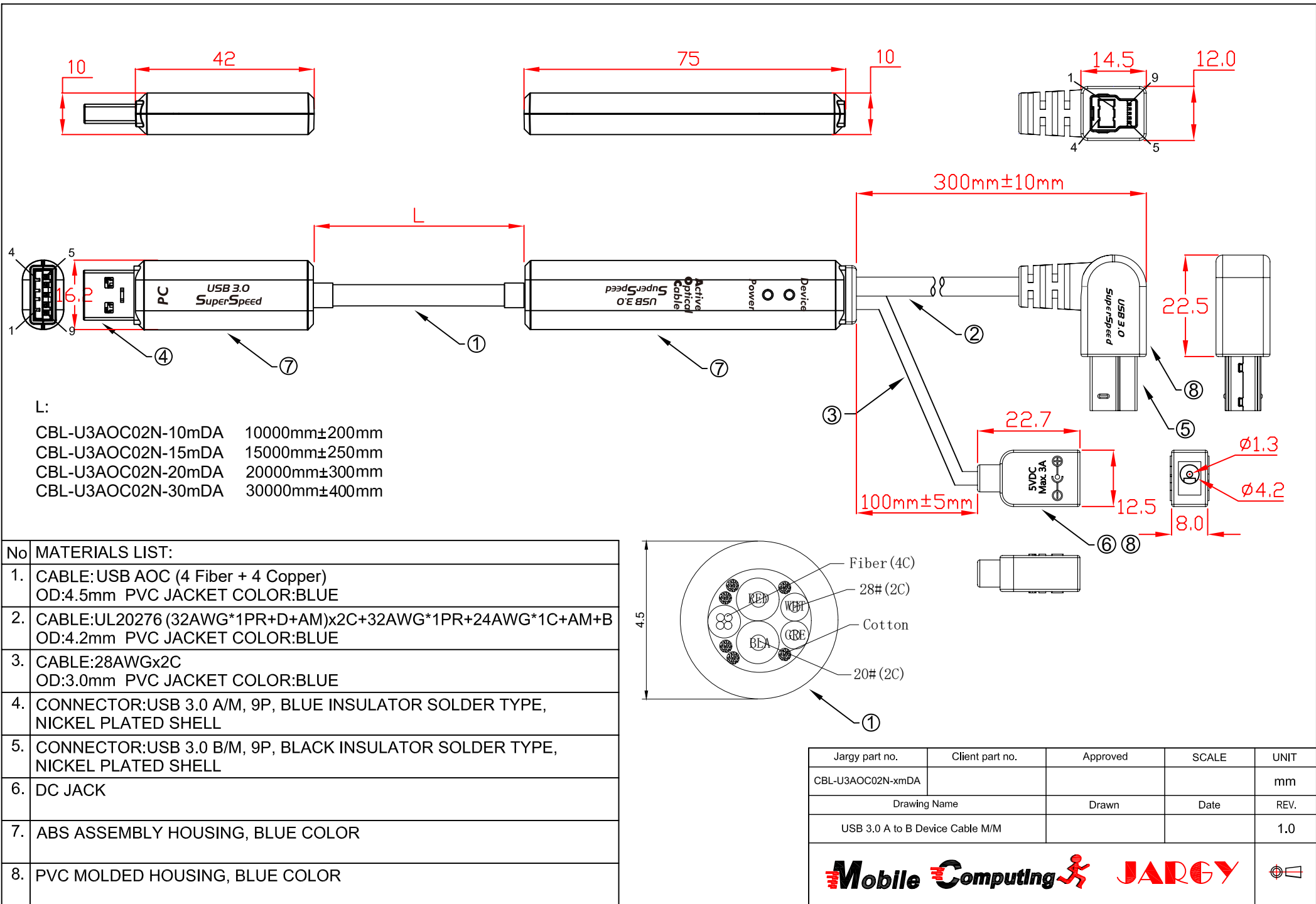

Jargy part no.	Client part no.	Approved	SCALE	UNIT
CBL-U3AOC02N-xmDA				mm
Drawing Name		Drawn	Date	REV.
USB 3.0 A to B Device Cable M/M				1.0

**Mobile Computing JARGY**